

Accesorii de montare pentru senzori inductivi

Clemă de montare pentru model M30

BST-30B

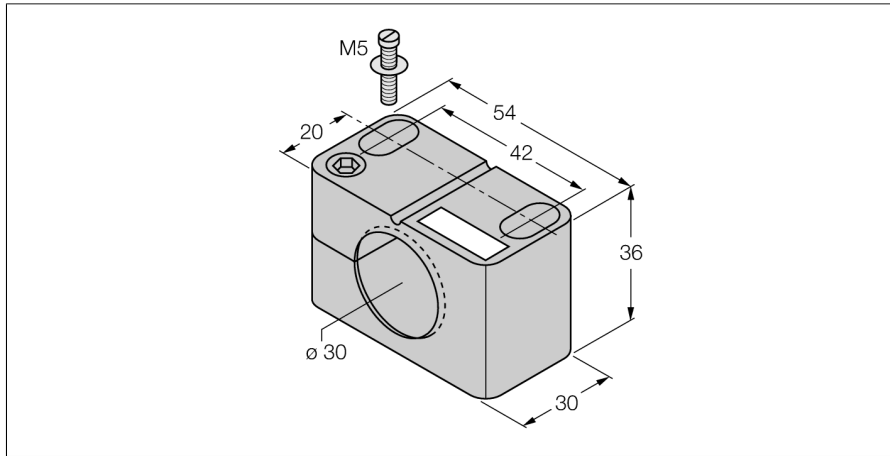

- Cu limitator de capăt
- Plastic PA6

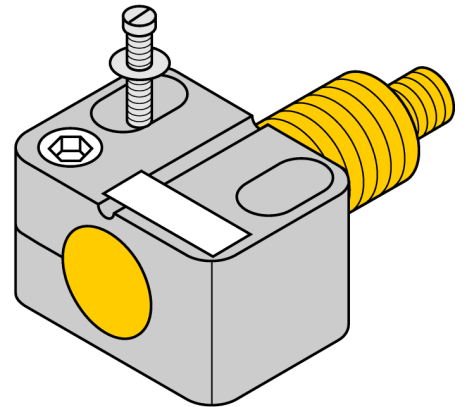

Tip	BST-30B
Nr. ID	6947216
Design	Accesorii pentru cilindri filetați, M30
Dimensiuni	30 x 54 x 36mm
Materialul carcasei	Plastic, PA6, Negru
Cuplul maxim de strângere a piuliței carcasei	1 Nm